

EE 340

Synchronous Generators I



Construction of synchronous machines

In a synchronous generator, a DC current is applied to the rotor winding. The rotor is then turned by a turbine to produce a rotating magnetic field, which induces 3-phase voltages within the stator windings.

- Field winding(rotor winding) - winding producing the rotor magnetic field
- Armature windings (stator windings)-windings where the stator voltages are induced

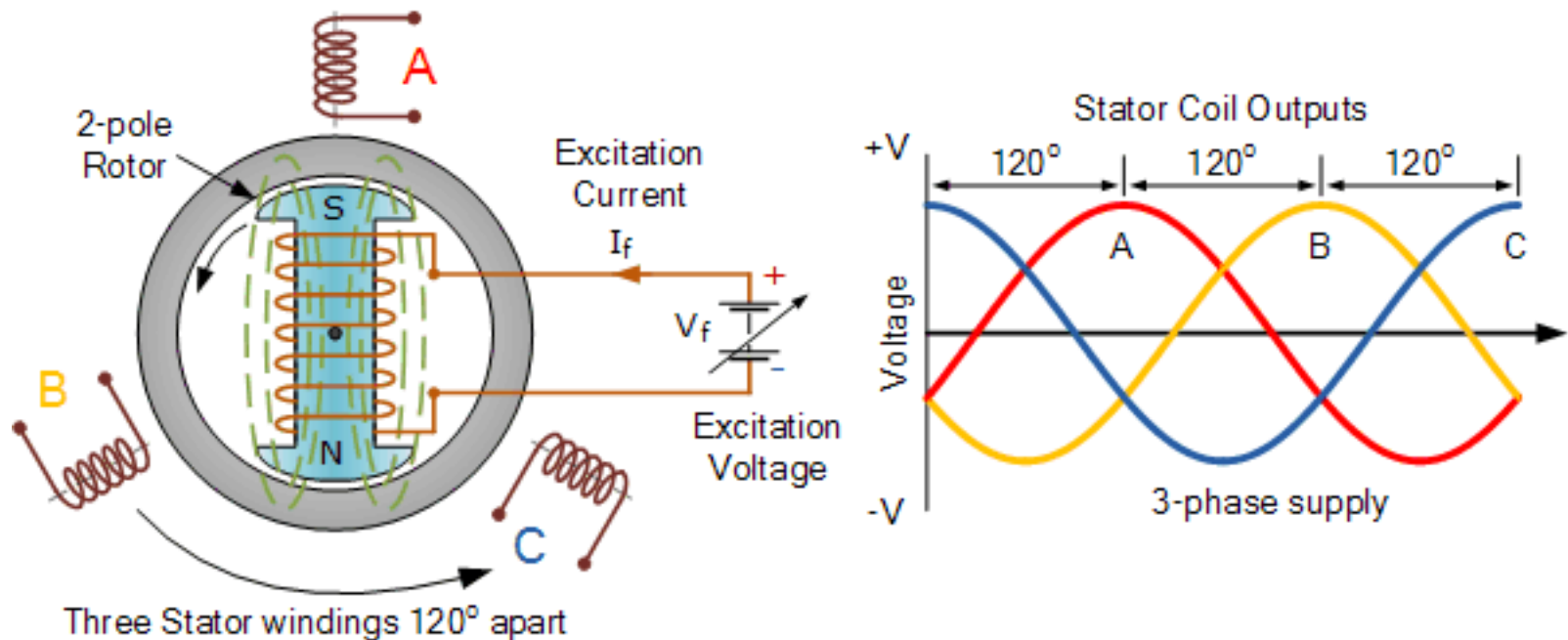

Construction of synchronous machines

The rotor of a synchronous machine is a large electromagnet. The magnetic poles can be either salient (sticking out of rotor surface) or non-salient construction.

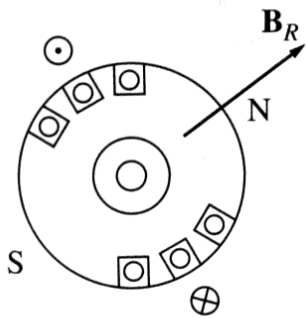

End view

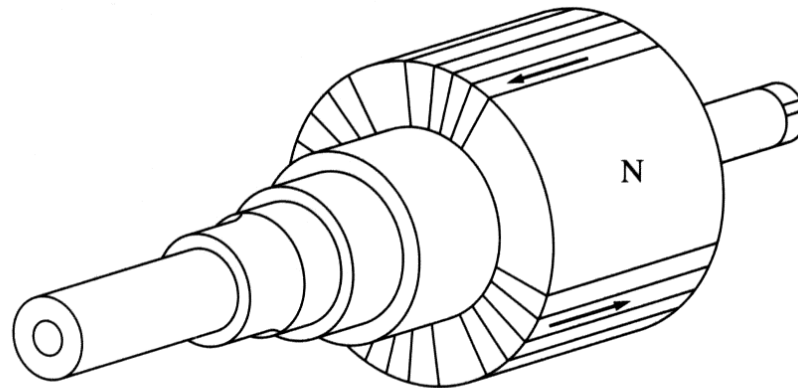

Side view



Non-salient-pole rotor: # of poles: 2 or 4.

Salient-pole rotor: # of poles: large number

Rotors are made laminated to reduce eddy current losses.

Construction of synchronous machines

Two common approaches are used to supply a DC current to the field winding on the rotating rotor:

1. Supply the DC power from an external DC source to the rotor by means of slip rings and brushes;
2. Supply the DC power from a special DC power source mounted directly on the shaft of the machine.



Slip rings are metal rings completely encircling the shaft of a machine but insulated from it. Graphite-like carbon brushes connected to DC terminals ride on each slip ring supplying DC voltage to field windings.

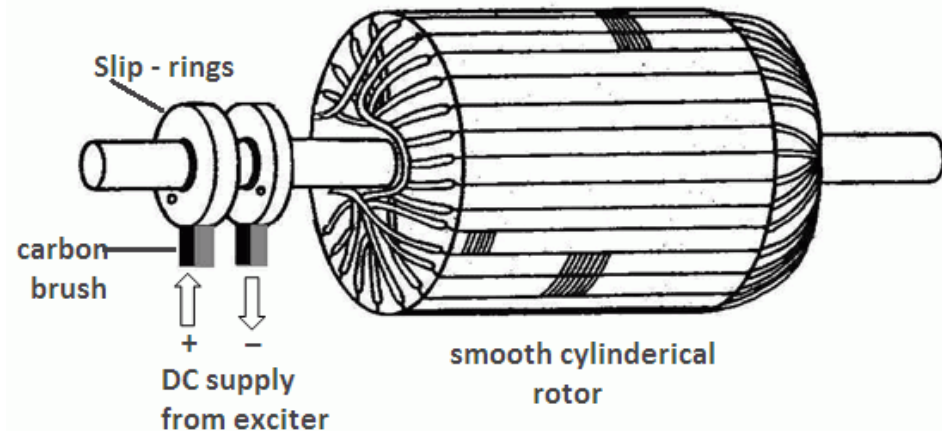

Construction of synchronous machines

- On large synchronous machines, brushless exciters are used.
 - A brushless exciter is a small AC generator whose field circuits are mounted on the stator and armature circuits are mounted on the rotor shaft.
 - The exciter generator's 3-phase output is rectified to DC by a 3-phase rectifier (mounted on the shaft) and fed into the main DC field circuit.
 - It is possible to adjust the field current on the main machine by controlling the small DC field current of the exciter generator (located on the stator).

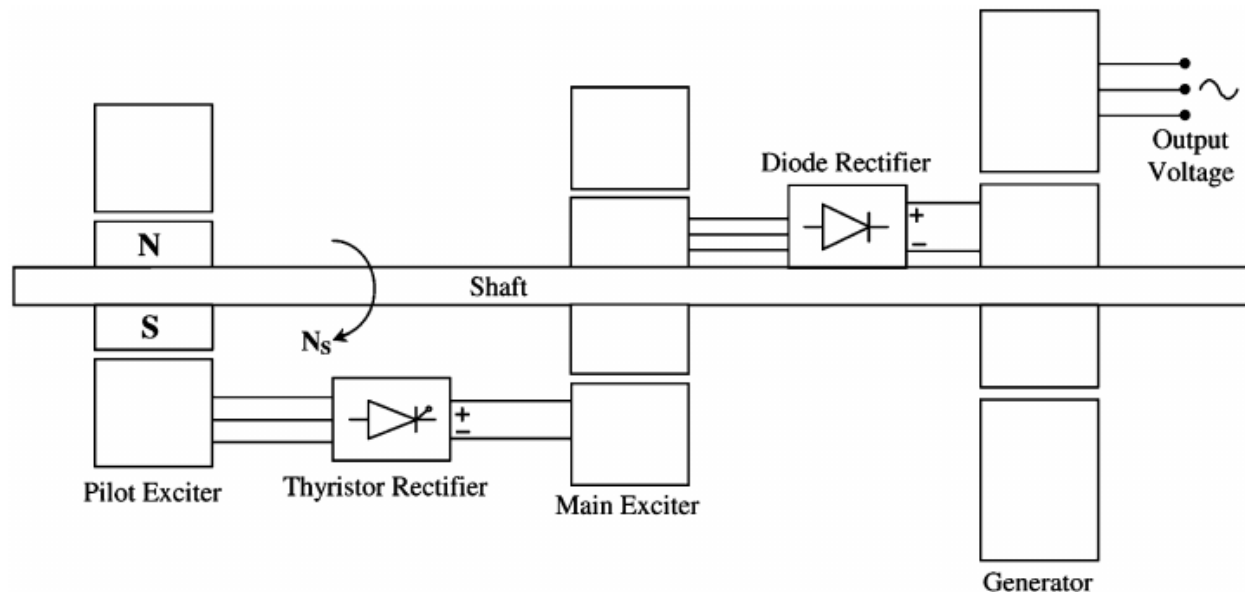

Construction of synchronous machines

To make the excitation of a generator completely independent of any external power source, a small pilot exciter is often added to the circuit.

The pilot exciter is an AC generator with a permanent magnet mounted on the rotor shaft and a 3-phase winding on the stator producing the power for the field circuit of the exciter.

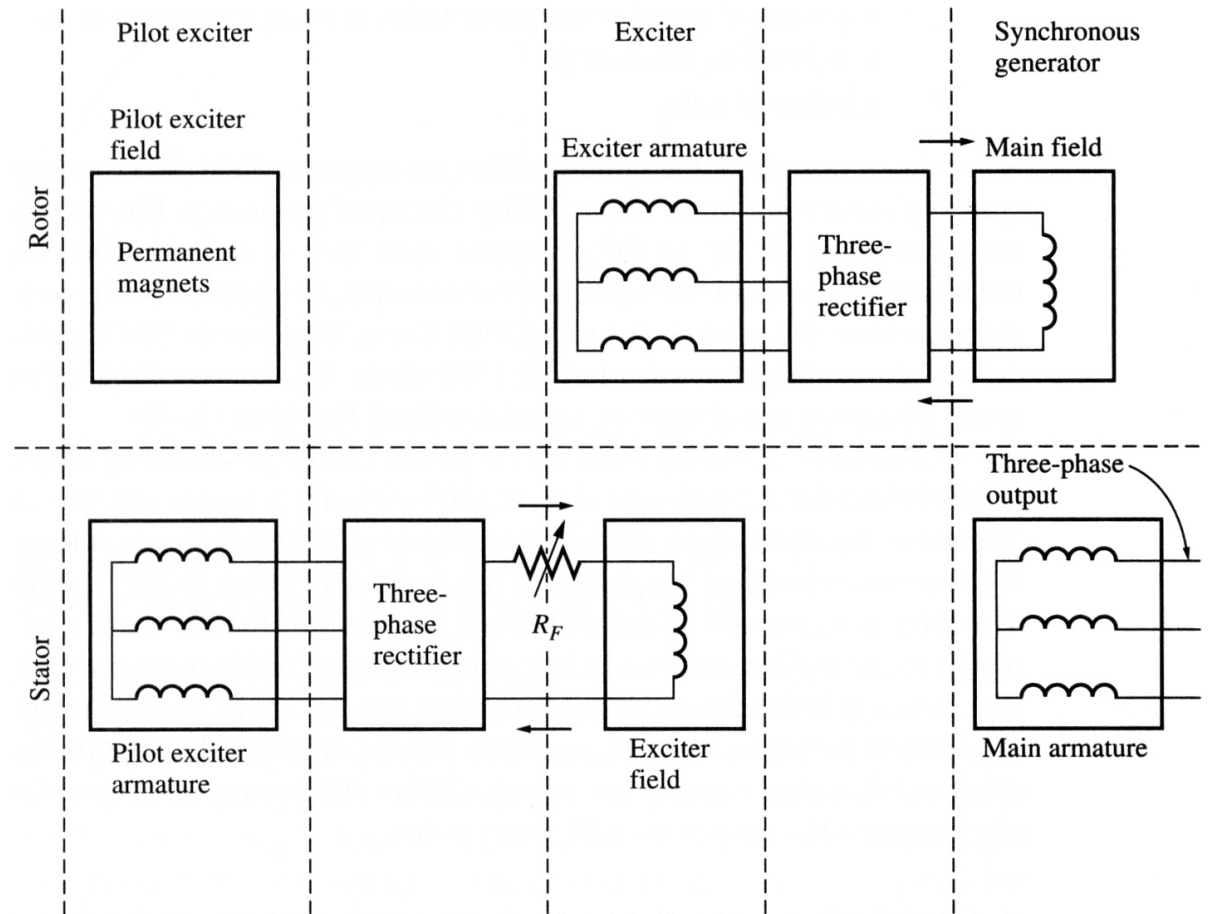

Construction of synchronous machines

A rotor of large synchronous machine with a brushless exciter mounted on the same shaft.

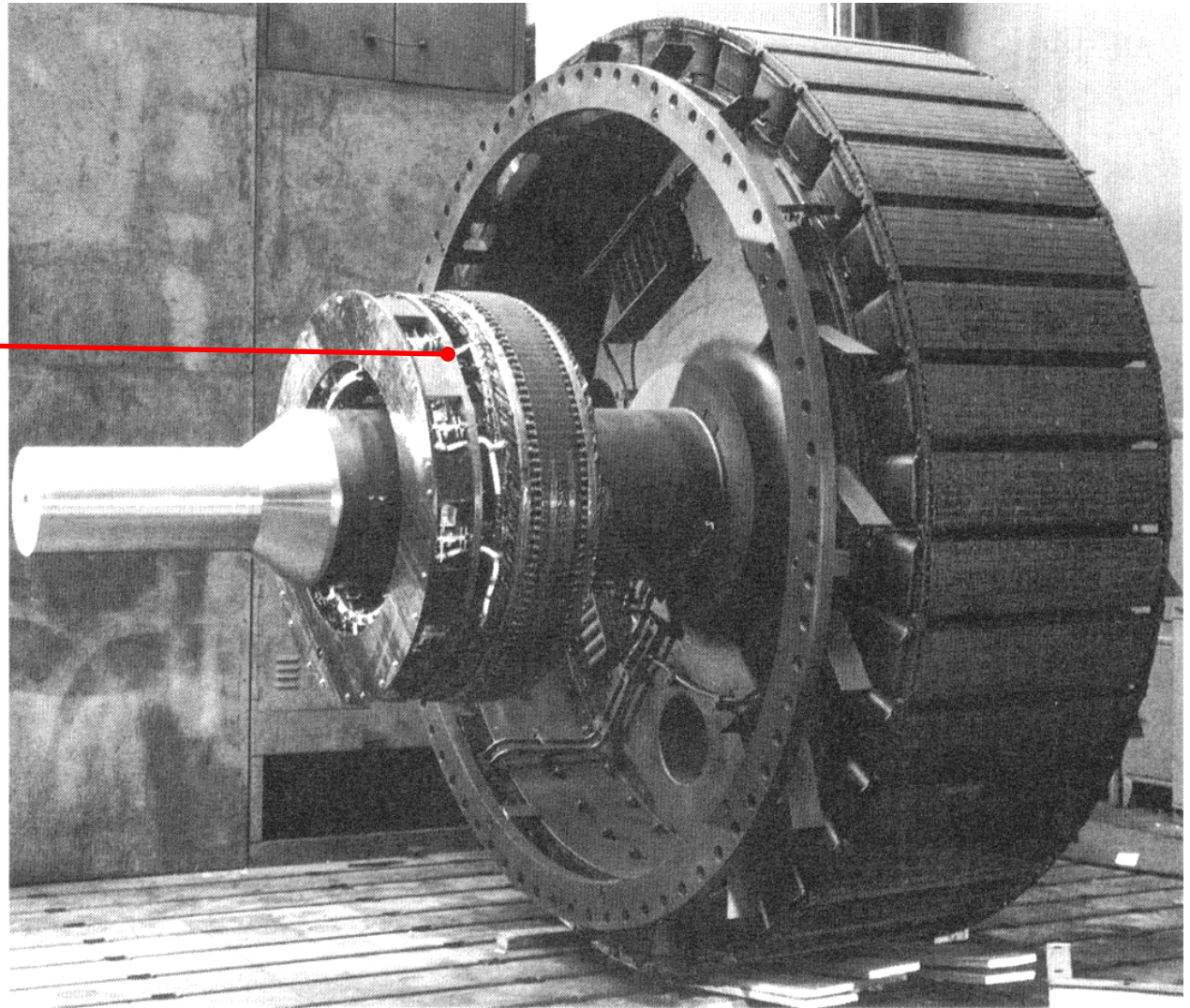

Construction of synchronous machines

Exciter

Rotor pole.

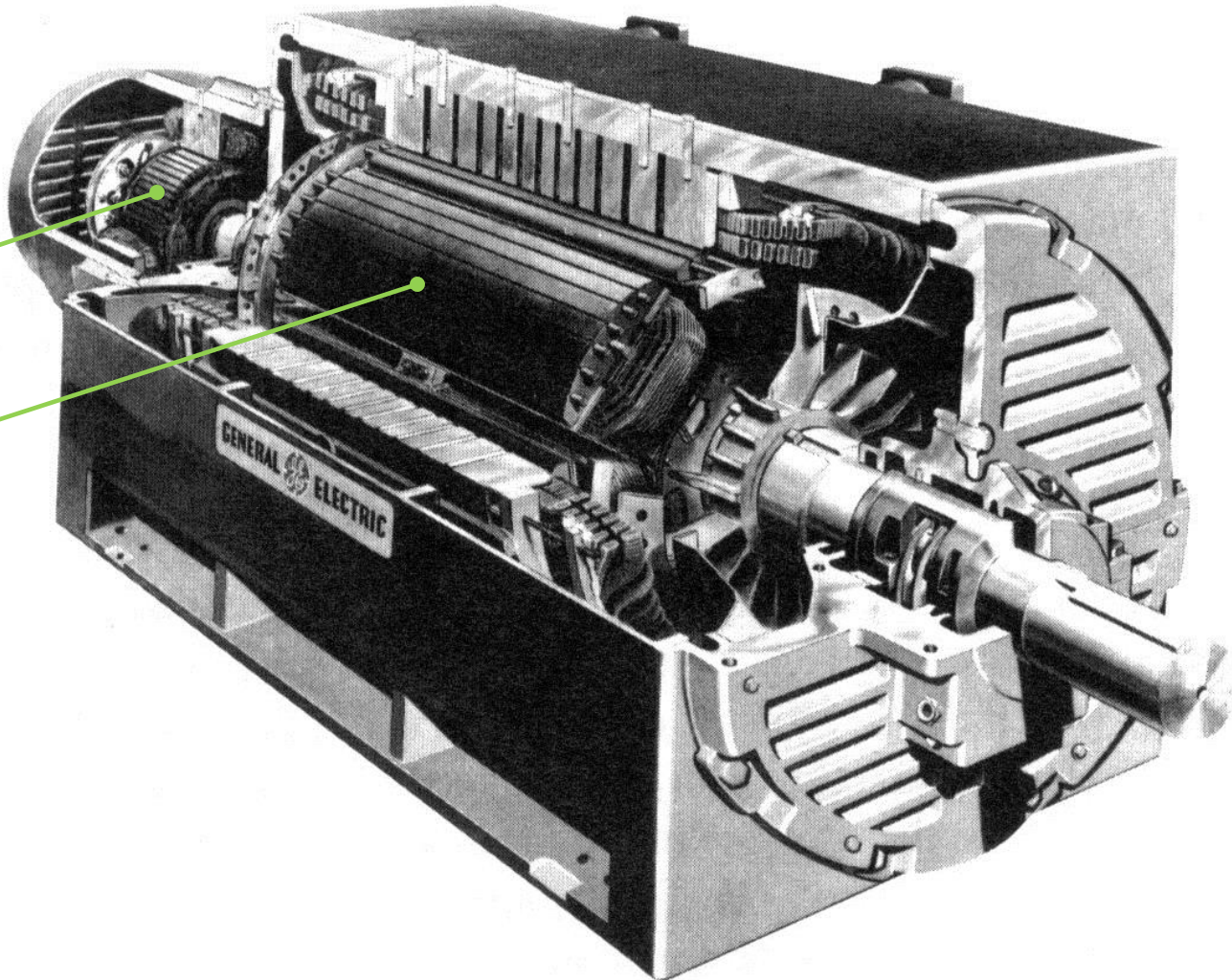

Rotation speed of synchronous generator

By the definition, synchronous generators produce electricity whose frequency is synchronized with the mechanical rotational speed.

$$\omega_e = \frac{p}{2} \omega_m \longrightarrow f_e = \frac{p}{120} n_m$$

Where f_e is the electrical frequency, Hz;
 n_m is the rotor speed of the machine,
 p is the number of poles.

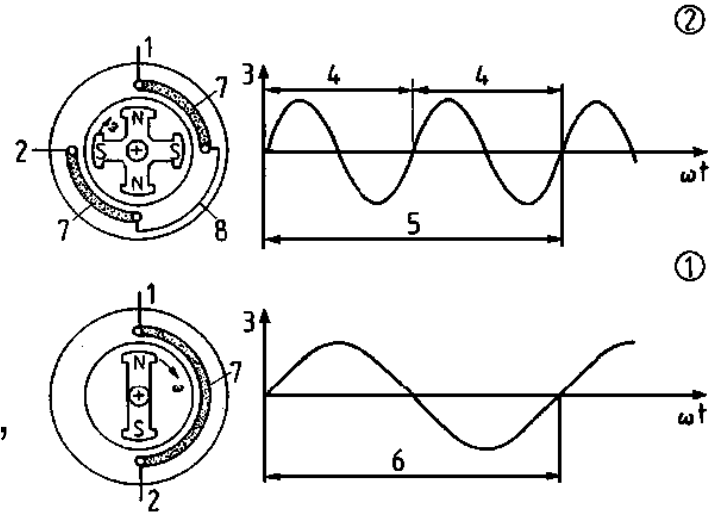

- Steam turbines are most efficient when rotating at high speed; therefore, to generate 60 Hz, they are usually rotating at 3600 rpm (2-pole).
- Water turbines are most efficient when rotating at low speeds (200-300 rpm); therefore, they usually turn generators with many poles.

The induced voltage in a 3-phase set of coils

In three coils, each of N_C turns, placed around the rotor magnetic field, the induced in each coil will have the same magnitude and phases differing by 120° :

$$e_{aa'}(t) = N_C \phi \omega_m \cos \omega_m t$$

$$e_{bb'}(t) = N_C \phi \omega_m \cos(\omega_m t - 120^\circ)$$

$$e_{cc'}(t) = N_C \phi \omega_m \cos(\omega_m t - 240^\circ)$$

Peak voltage:

$$E_{\max} = N_C \phi \omega_m$$

$$E_{\max} = 2\pi N_C \phi f$$

RMS voltage:

$$E_A = \frac{2\pi}{\sqrt{2}} N_C \phi f = \sqrt{2} \pi N_C \phi f$$

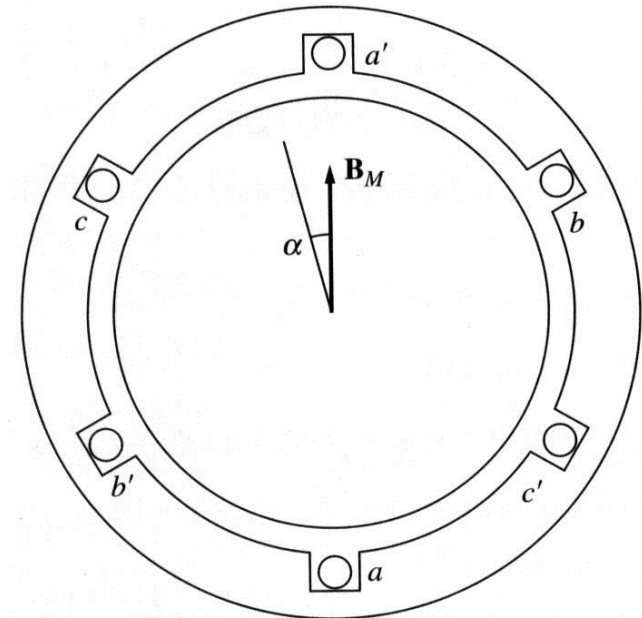

Internal generated voltage of a synchronous generator

The magnitude of internal generated voltage induced in a given stator is

$$E_A = \sqrt{2}\pi N_C \phi f = K \phi \omega$$

where K is a constant representing the construction of the machine, ϕ is flux in it and ω is its rotation speed.

Since flux in the machine depends on the field current through it, the internal generated voltage is a function of the rotor field current.

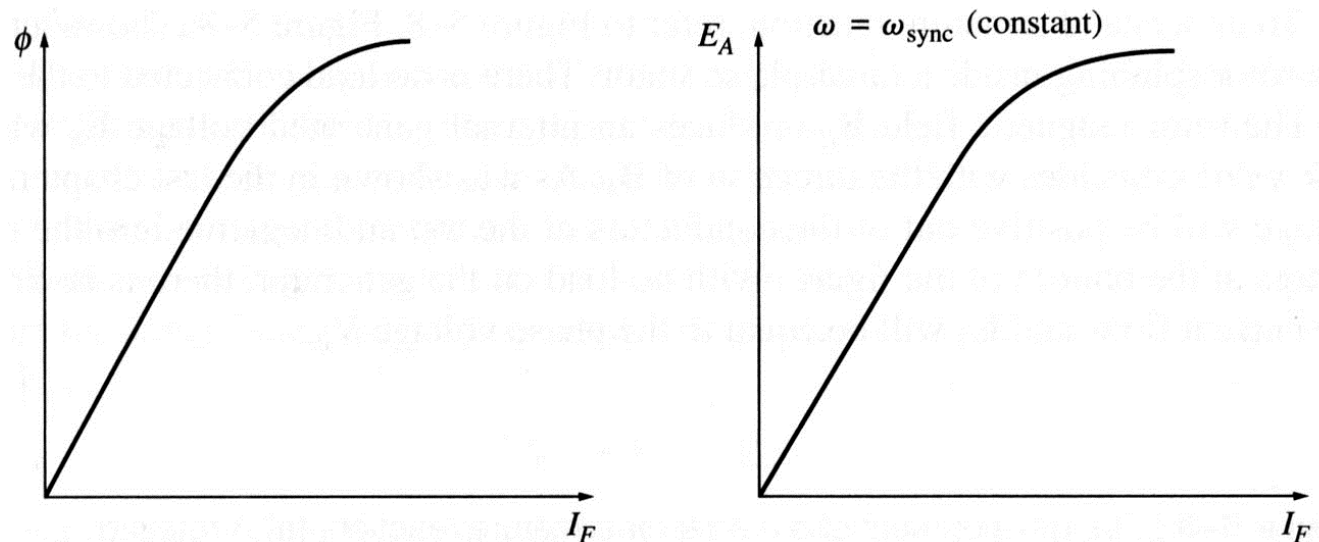

Magnetization curve (open-circuit characteristic) of a synchronous machine

Equivalent circuit of a synchronous generator

The internally generated voltage in a single phase of a synchronous machine E_A is not usually the voltage appearing at its terminals. It equals to the output voltage V_ϕ only when there is no armature current in the machine. The reasons that the armature voltage E_A is not equal to the output voltage V_ϕ are:

1. Distortion of the air-gap magnetic field caused by the current flowing in the stator (armature reaction);
2. Self-inductance of the armature coils;
3. Resistance of the armature coils;

Equivalent circuit of a synchronous generator

Armature reaction:

- When the rotor of a synchronous generator is spinning, a voltage E_A is induced in its stator.
- When a load is connected, a current starts flowing creating a magnetic field in machine's stator.
- This stator magnetic field B_S adds to the rotor (main) magnetic field B_R affecting the total magnetic field and, therefore, the phase voltage.

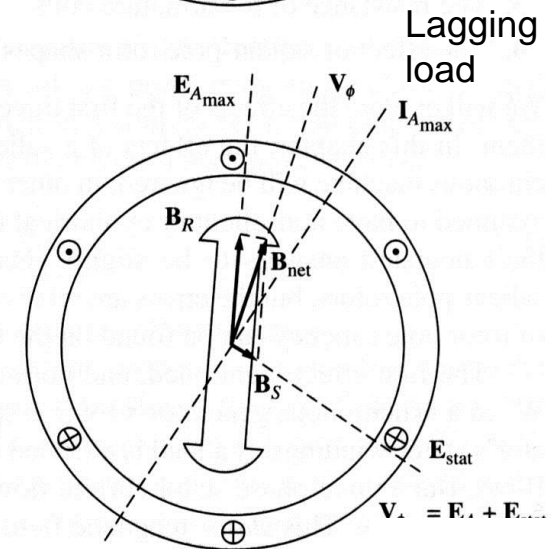
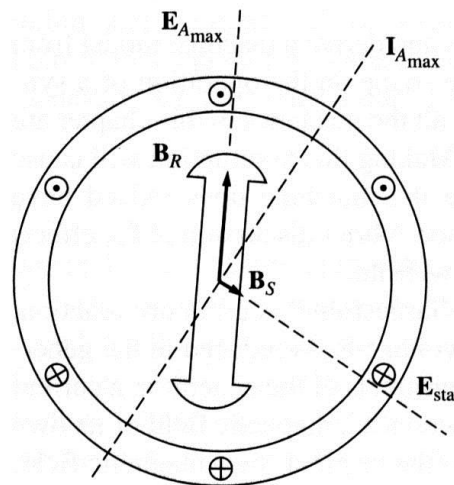
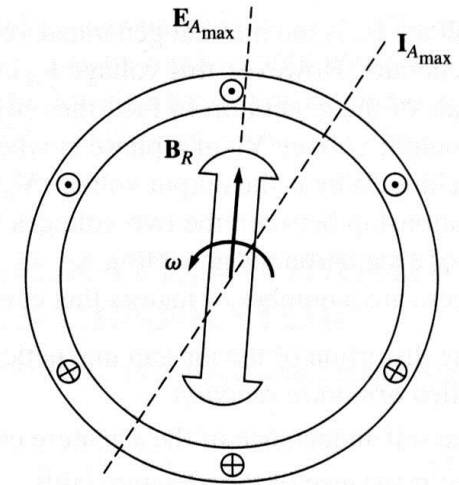
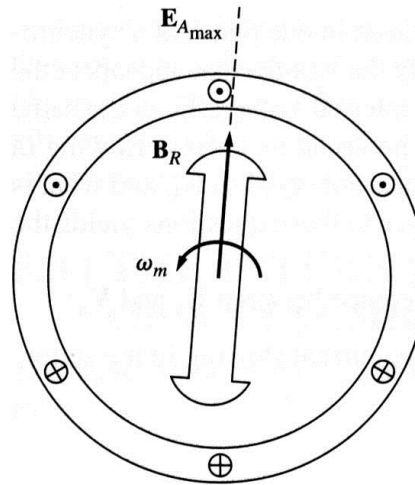

Equivalent circuit of a synchronous generator

The load current I_A will create a stator magnetic field B_S , which will produce the armature reaction voltage E_{stat} . Therefore, the phase voltage will be

$$V_\phi = E_A + E_{stat}$$

The net magnetic flux will be

$$B_{net} = B_R + B_S$$

Rotor field

Stator field

Equivalent circuit of a synchronous generator

Since the armature reaction voltage lags the current by 90 degrees, it can be modeled by

$$E_{stat} = -jXI_A$$

The phase voltage is then

$$V_\phi = E_A - jXI_A$$

However, in addition to armature reactance effect, the stator coil has a self-inductance L_A (X_A is the corresponding reactance) and the stator has resistance R_A . The phase voltage is thus

$$V_\phi = E_A - jXI_A - jX_A I_A - RI_A$$

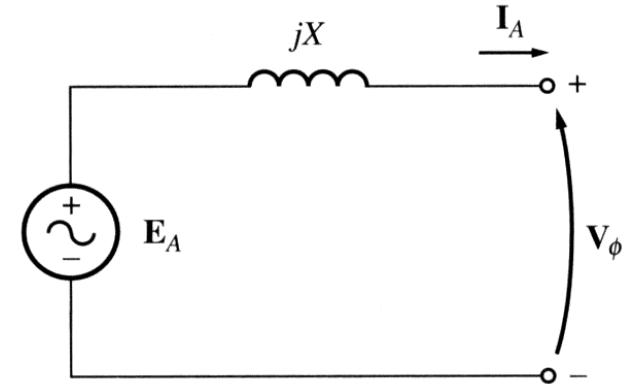

Equivalent circuit of a synchronous generator

Often, armature reactance and self-inductance are combined into the synchronous reactance of the machine:

$$X_S = X + X_A$$

Therefore, the phase voltage is

$$V_\phi = E_A - jX_S I_A - R I_A$$

The equivalent circuit of a 3-phase synchronous generator is shown.

The adjustable resistor R_{adj} controls the field current and, therefore, the rotor magnetic field.

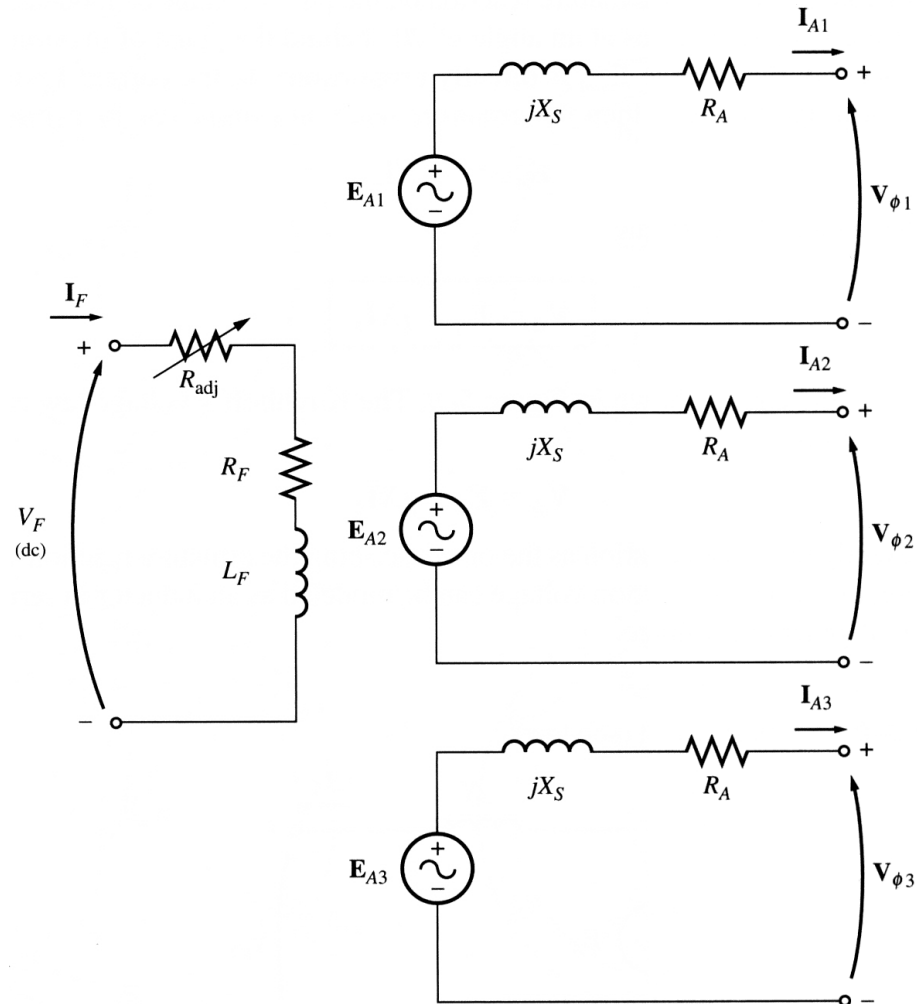

Equivalent circuit of a synchronous generator

A synchronous generator is connected in Y.

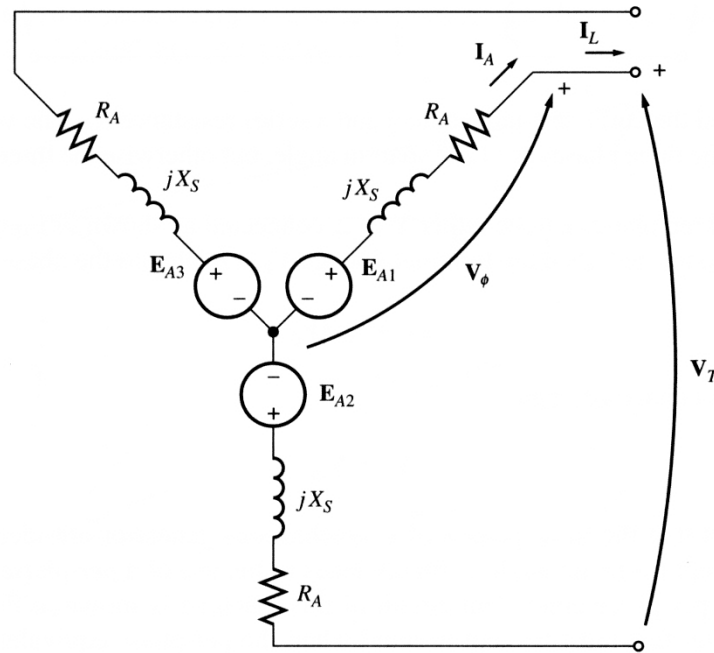

The line-to-line voltage is equal to $\sqrt{3}$ times the phase voltage.

Equivalent circuit of a synchronous generator

Since – for balanced loads – the three phases of a synchronous generator are identical except for phase angles, per-phase equivalent circuits are often used.

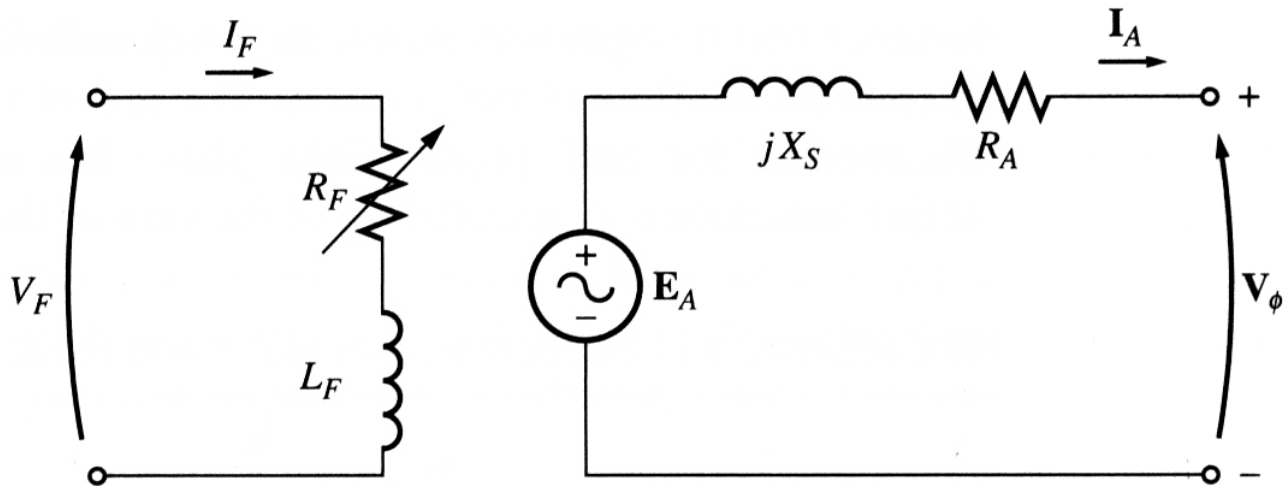

Measuring parameters of synchronous generator model

Three quantities must be determined in order to describe the generator model:

- The armature resistance which can simply be measured by an Ohm-meter,
- The relationship between field current and flux (and therefore between the field current I_F and the internal generated voltage E_A);
- The synchronous reactance;

Open Circuit Test

The generator is rotated at the rated speed,

- The terminals are open
- The field current is set to zero first. Then it is increased in steps and the phase voltage (which is equal to the internal generated voltage E_A since the armature current is zero) is measured.

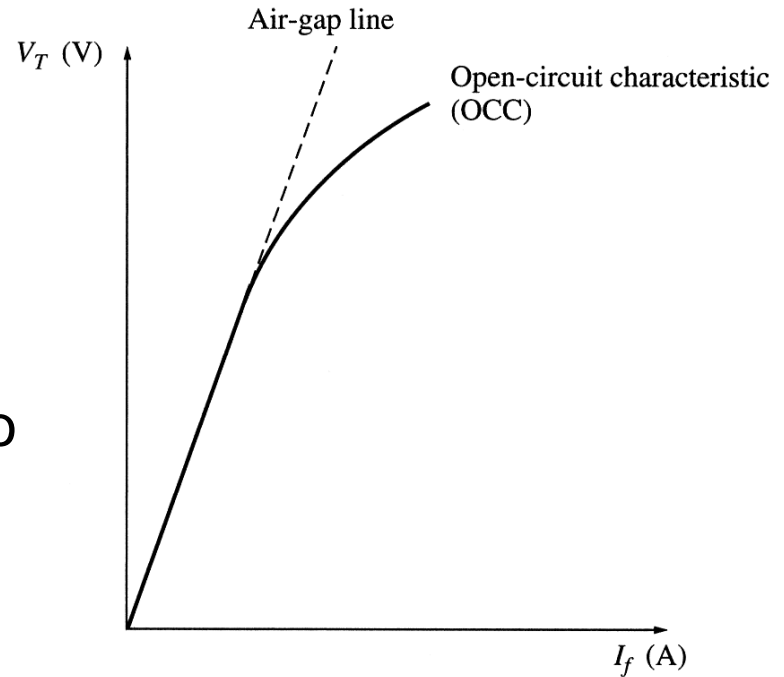

Since the unsaturated core of the machine has a reluctance thousands times lower than the reluctance of the air-gap, the resulting flux increases linearly first. When the saturation is reached, the core reluctance greatly increases causing the flux to increase much slower with the increase of the mmf.

Short Circuit Test

In the short-circuit test,

1. the generator is rotated at the rated speed, with the field current is set to zero first, and all the terminals are short-circuited.
2. Next, the field current is increased in steps and the armature current I_A (i.e., short circuit current) is measured as the field current is increased.

The plot of armature current vs. the field current is referred to as the short-circuit characteristic (SCC) of the generator.

Short Circuit Test

The SCC is a straight line since, for the short-circuited terminals, the magnitude of the armature current is

$$I_A = \frac{E_A}{\sqrt{R_A^2 + X_S^2}}$$

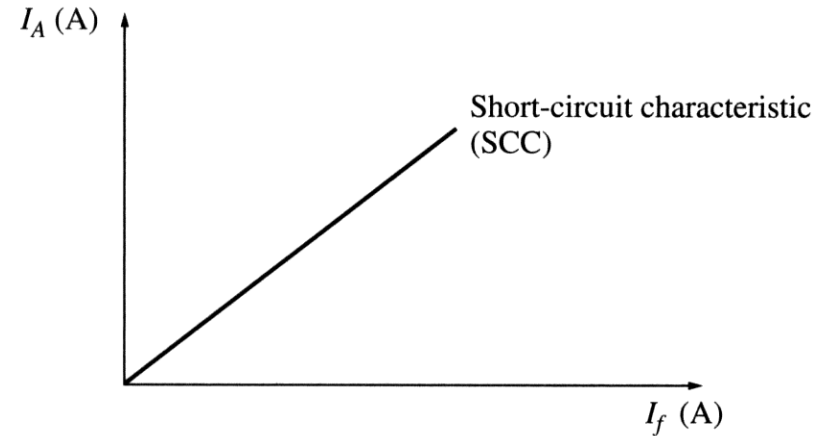

The equivalent generator's circuit during SC

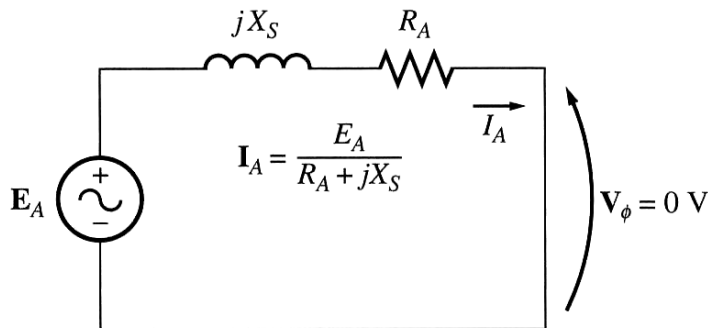

The resulting phasor diagram

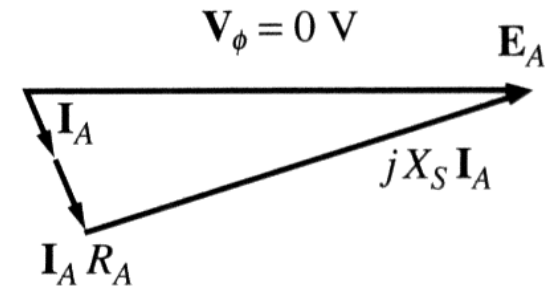

SCC and OCC Curves

For each value of the field current, one can determine the synchronous reactance X_S as follows:

- Draw a vertical line and read the corresponding generated voltage E_A and short-circuit current I_A .
- Determine the generator internal impedance

$$Z = \sqrt{R_A^2 + X_S^2} = \frac{E_A}{I_A}$$

- Determine the synchronous reactance

$$X_S = \sqrt{Z^2 - R_A^2}$$

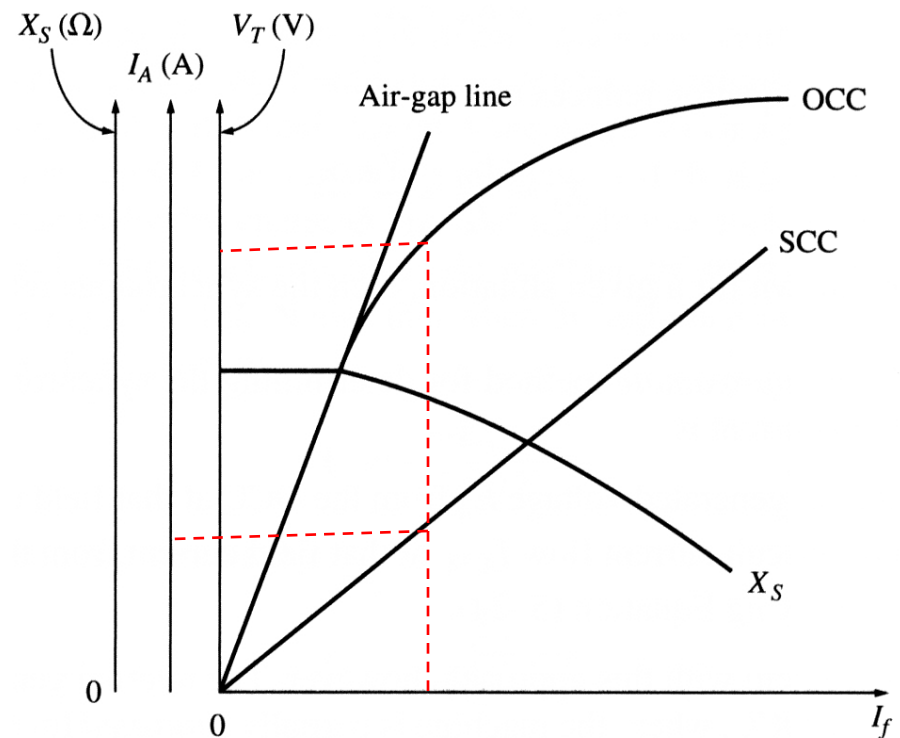

Example

Example 7.1: A 200 kVA, 480 V, 50 Hz, Y-connected synchronous generator with a rated field current of 5 A was tested and the following data were obtained:

1. $V_{T,OC} = 540$ V at the rated I_F .
2. $I_{L,SC} = 300$ A at the rated I_F .
3. The armature winding resistance is 0.2 .

Find the generator's model at the rated conditions (i.e., the armature resistance and the approximate synchronous reactance).

The internal generated voltage at the rated field current is

$$E_A = V_{\phi,OC} = \frac{V_T}{\sqrt{3}} = \frac{540}{\sqrt{3}} = 311.8 \text{ V}$$

Synchronous reactance at the rated field current

$$X_S = \sqrt{Z_S^2 - R_A^2} = \sqrt{\frac{E_A^2}{I_{A,SC}^2} - R_A^2} = \sqrt{\frac{311.8^2}{300^2} - 0.2^2} = 1.02 \Omega$$

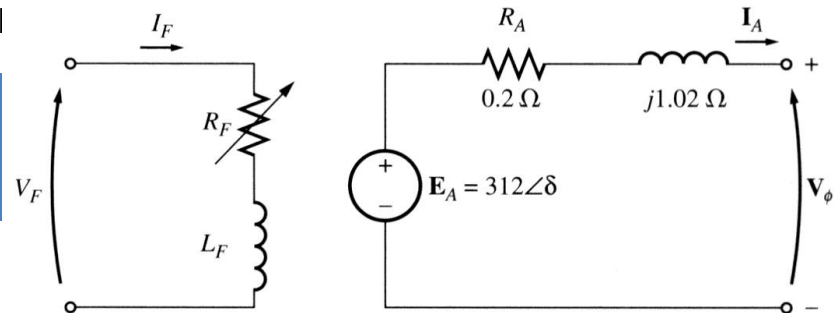

Phasor diagram of a synchronous generator (similar to that of a transformer)

Since the voltages in a synchronous generator are AC voltages, they are usually expressed as phasors. A vector plot of voltages and currents within one phase is called a phasor diagram.

A phasor diagram of a synchronous generator with a unity power factor (resistive load)

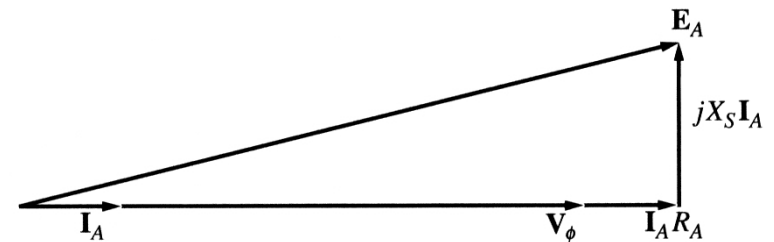

Lagging power factor (inductive load): a larger than for leading PF internal generated voltage E_A is needed to form the same phase voltage.

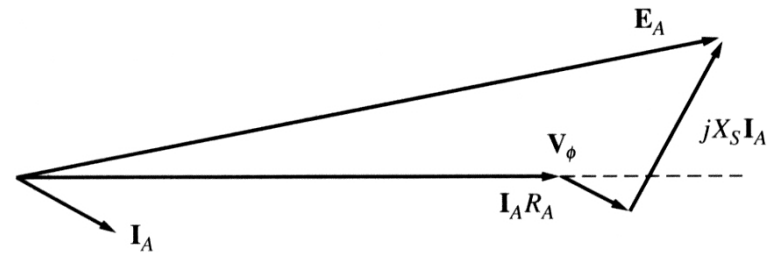

Leading power factor (capacitive load).

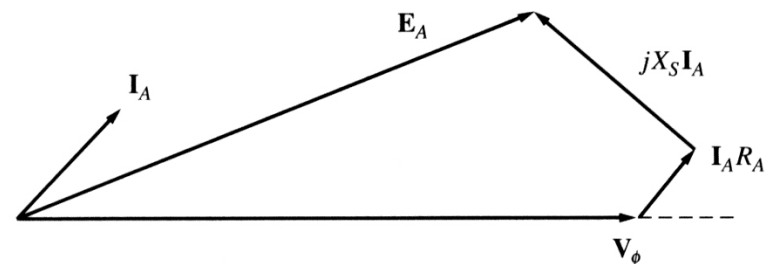

The Synchronous generator operating alone

The behavior of a synchronous generator varies greatly under load depending on the power factor of the load and on whether the generator is working alone or in parallel with other synchronous generators.

Although most of the synchronous generators in the world operate as parts of large power systems, we start our discussion assuming that the synchronous generator works alone.

Unless otherwise stated, the speed of the generator is assumed constant.

The Synchronous generator operating alone

A increase in the load results an increase in the real and/or reactive power drawn from the generator.

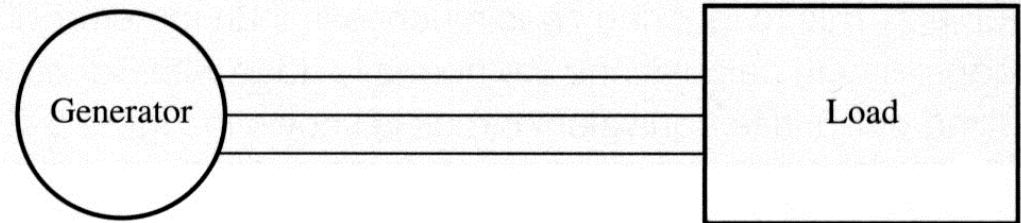

Since the field resistor is unaffected, the field current is constant and, therefore, the flux ϕ is constant too. Since the speed is assumed as constant, the magnitude of the internal generated voltage also constant.

Assuming a constant power factor of the load, and a negligible stator winding resistance, a change in load will change the magnitude of the armature current I_A . Thus, the armature reaction voltage $jX_S I_A$ will be larger for the increased load. Since the magnitude of the internal generated voltage is constant

$$E_A = V_\phi + jX_S I_A$$

Armature reaction voltage vector will move “in parallel” to its initial position.

The Synchronous generator operating alone

Increase load effect on generators with

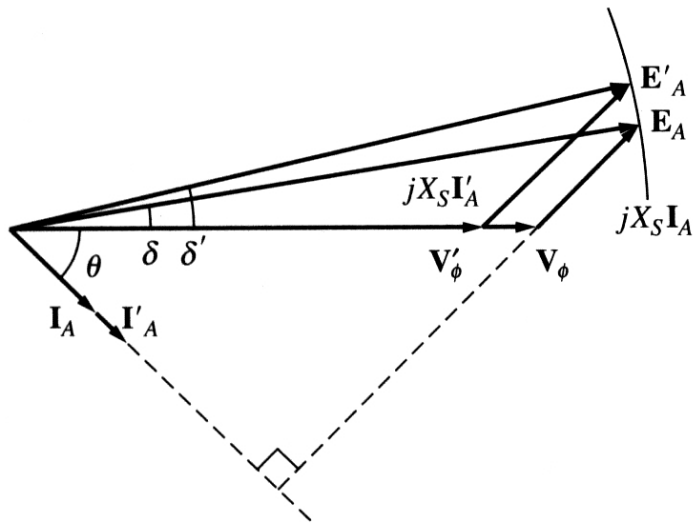

Lagging PF

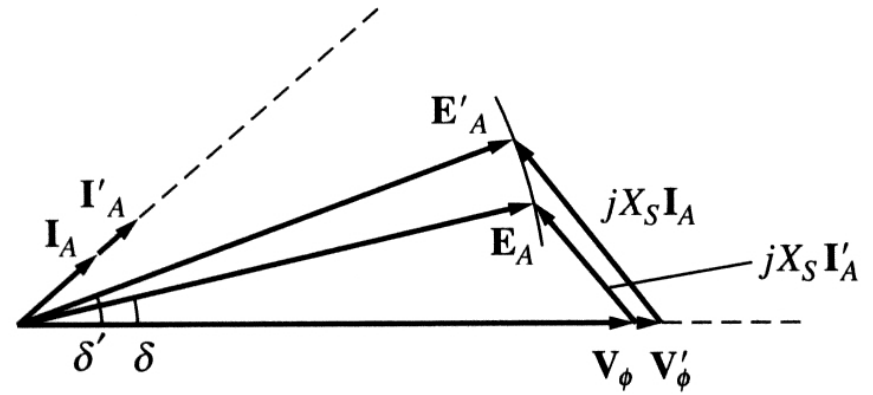

Leading PF

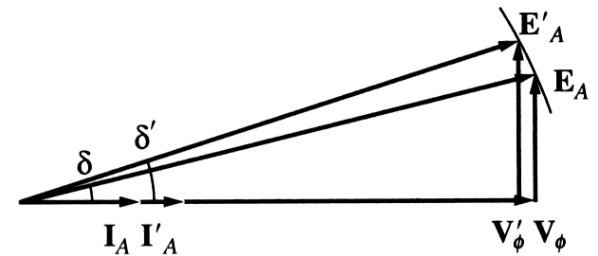

Unity PF

The Synchronous generator operating alone

Generally, when a load on a synchronous generator is increased, the following changes can be observed:

1. For lagging (inductive) loads, the phase (and terminal) voltage decreases significantly.
2. For unity power factor (purely resistive) loads, the phase (and terminal) voltage decreases slightly.
3. For leading (capacitive) loads, the phase (and terminal) voltage rises.

Effects of adding loads can be described by the voltage regulation:

$$VR = \frac{V_{nl} - V_{fl}}{V_{fl}} 100\%$$

Where V_{nl} is the no-load voltage of the generator and V_{fl} is its full-load voltage.

The Synchronous generator operating alone

- A synchronous generator operating at a lagging power factor has a fairly large positive voltage regulation.
- A synchronous generator operating at a unity power factor has a small positive voltage regulation.
- A synchronous generator operating at a leading power factor often has a negative voltage regulation.

Normally, a constant terminal voltage supplied by a generator is desired. Since the armature reactance cannot be controlled, an obvious approach to adjust the terminal voltage is by controlling the internal generated voltage $E_A = K\phi\omega$. This may be done by changing flux in the machine while varying the value of the field resistance R_F , which is summarized as follows:

1. Decreasing the field resistance increases the field current in the generator.
2. An increase in the field current increases the flux in the machine.
3. An increased flux leads to the increase in the internal generated voltage.
4. An increase in the internal generated voltage increases the terminal voltage of the generator.

Power and torque in synchronous generators

A synchronous generator needs to be connected to a prime mover whose speed is reasonably constant (to ensure constant frequency of the generated voltage) for various loads.

The applied mechanical power

$$P_{in} = \tau_{app} \omega_m$$

is partially converted to electricity

$$P_{conv} = \tau_{ind} \omega_m = 3E_A I_A \cos \gamma$$

Where γ is the angle between E_A and I_A .

The power-flow diagram of a synchronous generator.

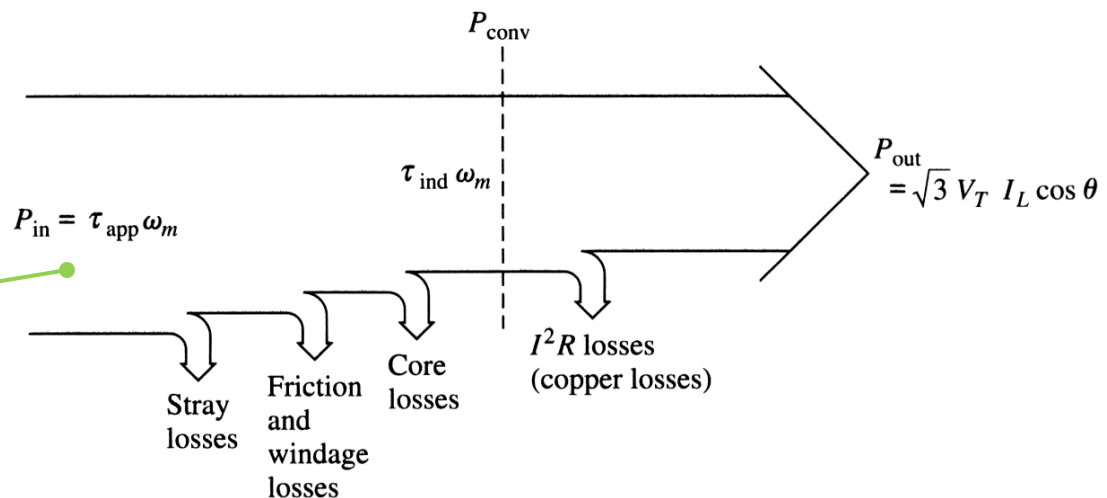

Power and torque in synchronous generators

The real output power of the synchronous generator is

$$P_{out} = \sqrt{3}V_T I_L \cos \theta = 3V_\phi I_A \cos \theta$$

The reactive output power of the synchronous generator is

$$Q_{out} = \sqrt{3}V_T I_L \sin \theta = 3V_\phi I_A \sin \theta$$

Recall that the power factor angle θ is the angle between V_ϕ and I_A and **not** the angle between E_A and I_A .

In real synchronous machines of any size, the armature resistance $R_A \ll X_S$ and, therefore, the armature resistance can often be ignored. Thus, a simplified phasor diagram indicates that

$$I_A \cos \theta = \frac{E_A \sin \delta}{X_S}$$

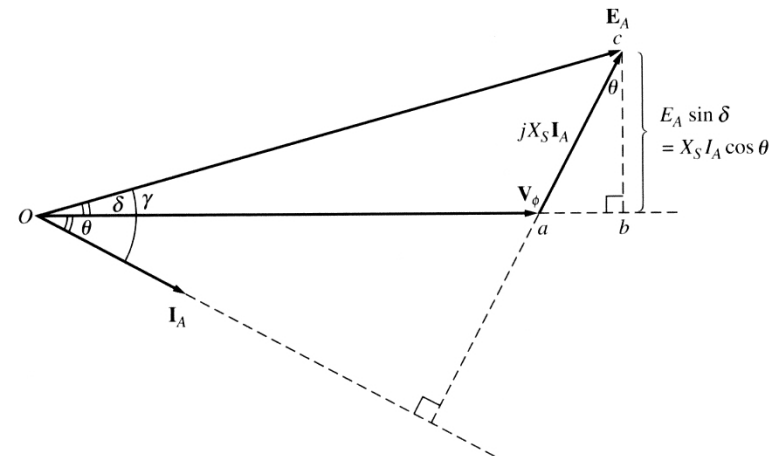

Power and torque in synchronous generators

Then the real output power of the synchronous generator can be approximated as

$$P_{out} \approx \frac{3V_{\phi} E_A \sin \delta}{X_S}$$

We observe that electrical losses are assumed to be zero since the resistance is neglected. Therefore:

$$P_{conv} \approx P_{out}$$

Here δ is the power angle of the machine – the angle between V_{ϕ} and E_A . This is Different from the power factor angle.

The maximum power can be supplied by the generator when $\delta = 90^\circ$:

$$P_{max} = \frac{3V_{\phi} E_A}{X_S}$$

Diesel Engine - Generator

- Engine: Isuzu 3CE1-BGZG1 (3 cylinder)
- Fuel consumption: 0.25 liter/kWh (at rated power)
- Generator power rating: 20 kVA at 0.8 PF, 120/208V
- 1,800 rpm (4 pole)
- AVR powered by auxiliary winding in the stator

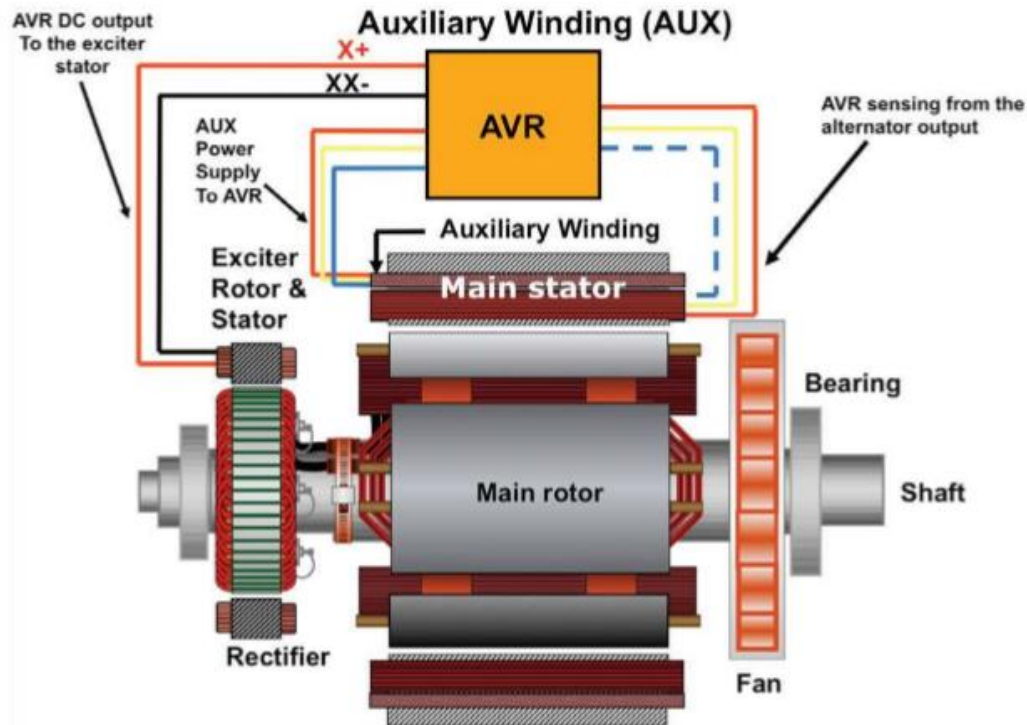

Diesel generator Speed and voltage Controls

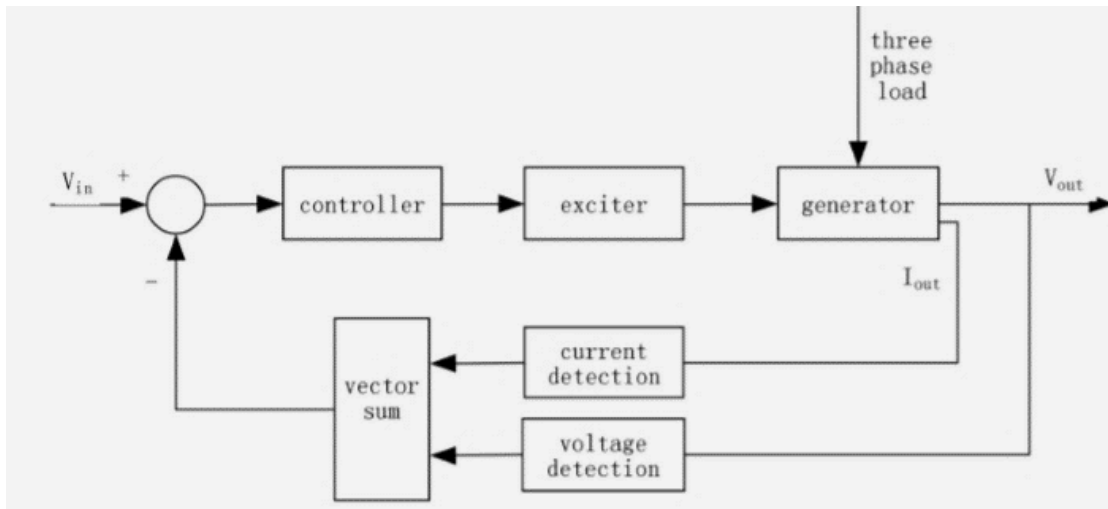

DSE-A106 Digital AVR

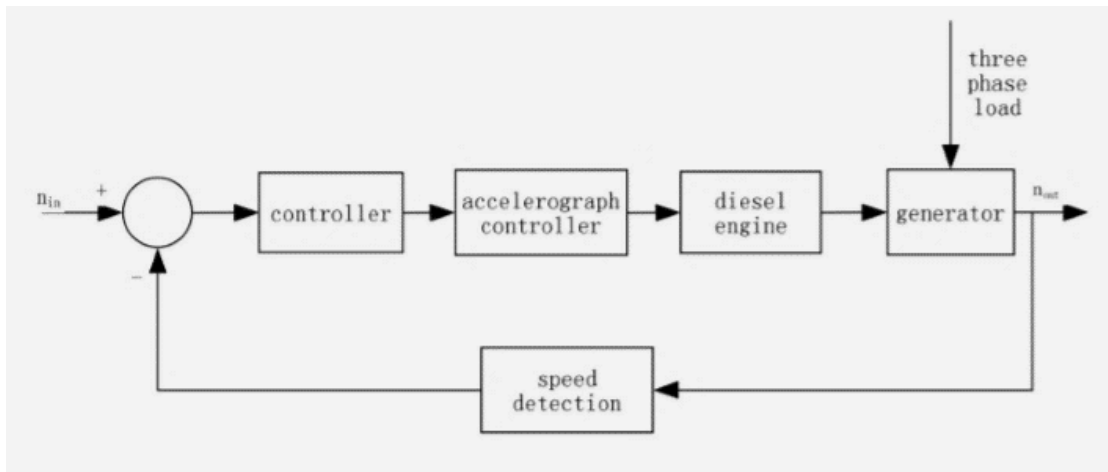
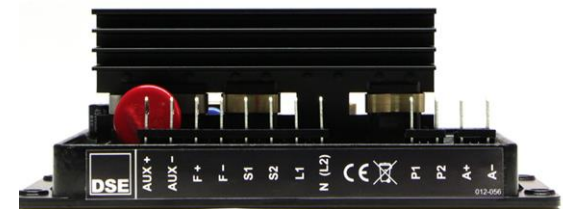

DPG-2223 Digital Governor



Voltage and frequency response to sudden 12 kW increase in load

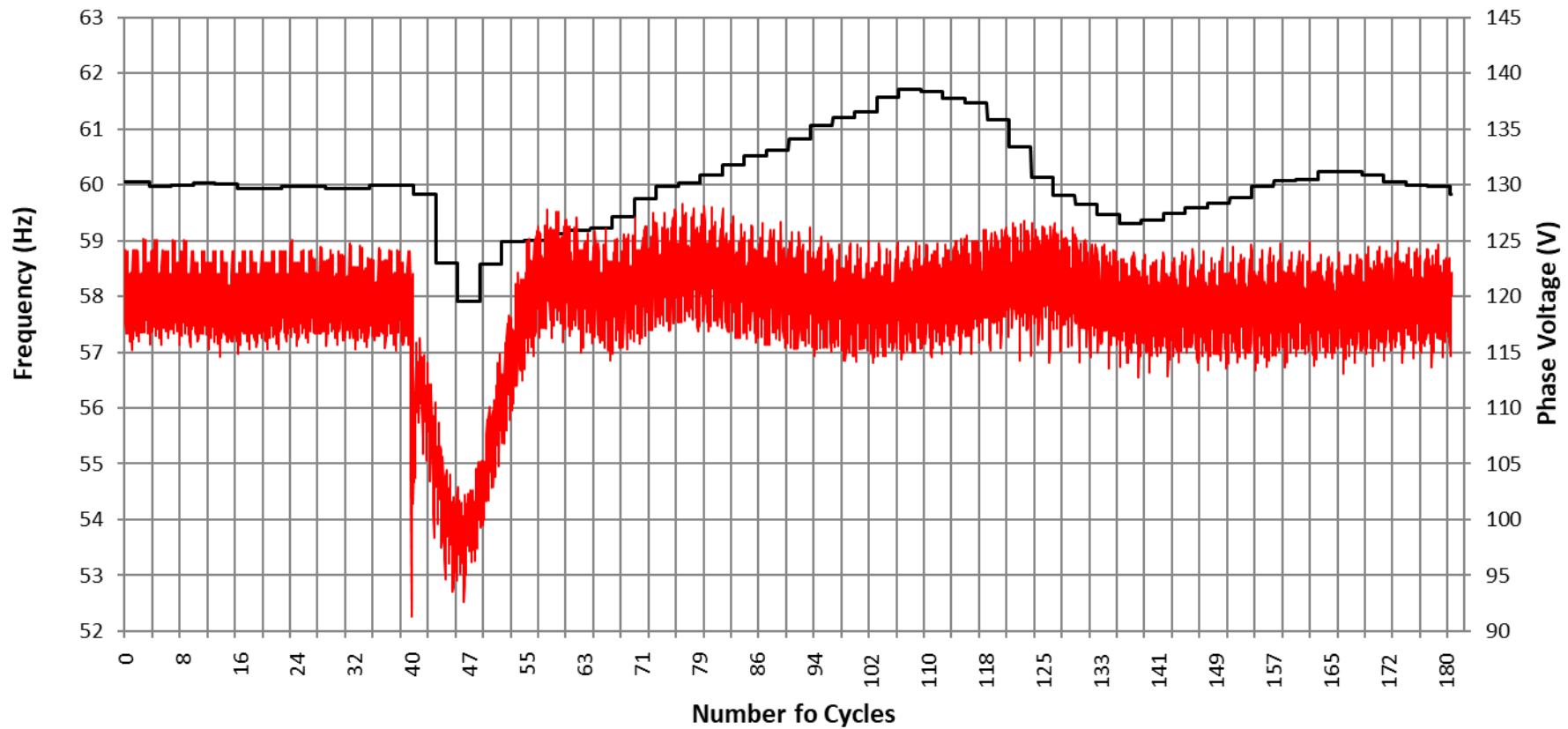

Problems (Chap 5)

- 2-4, 5-14, 15, 16, 17,